

CHN-900/CHNS-932, VTF-900 Consumables & Spare Parts Reference Card

Note: Part numbers and standards' values may change. Consult LECO for the latest information.

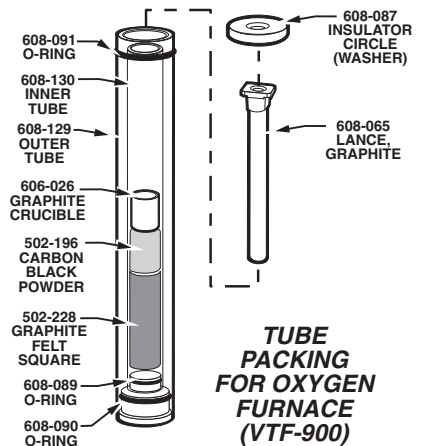
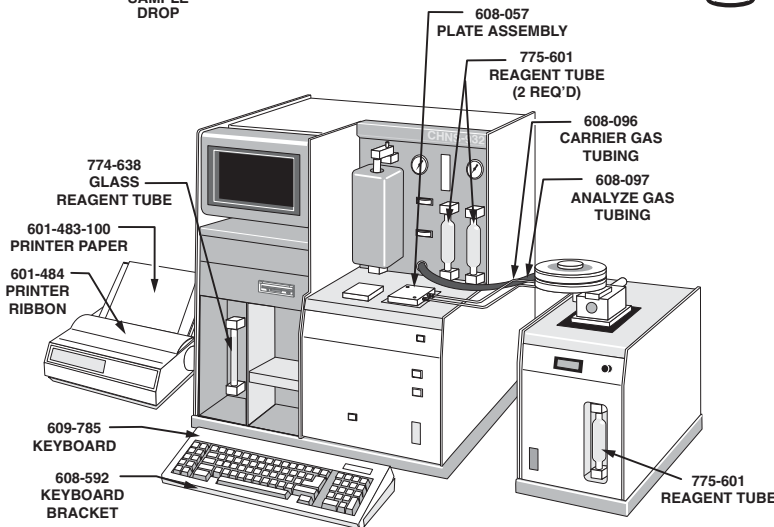
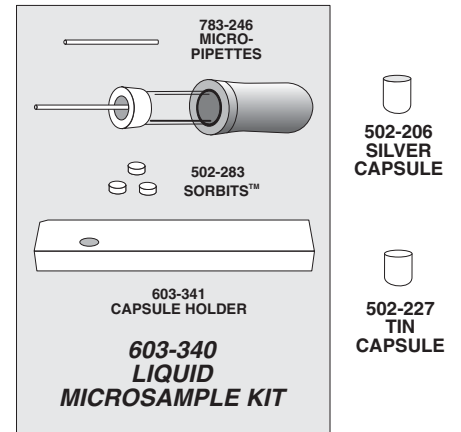
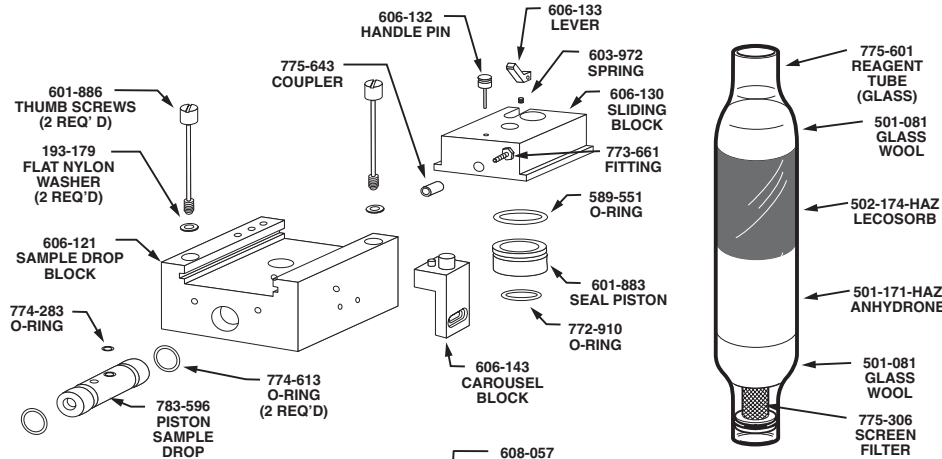
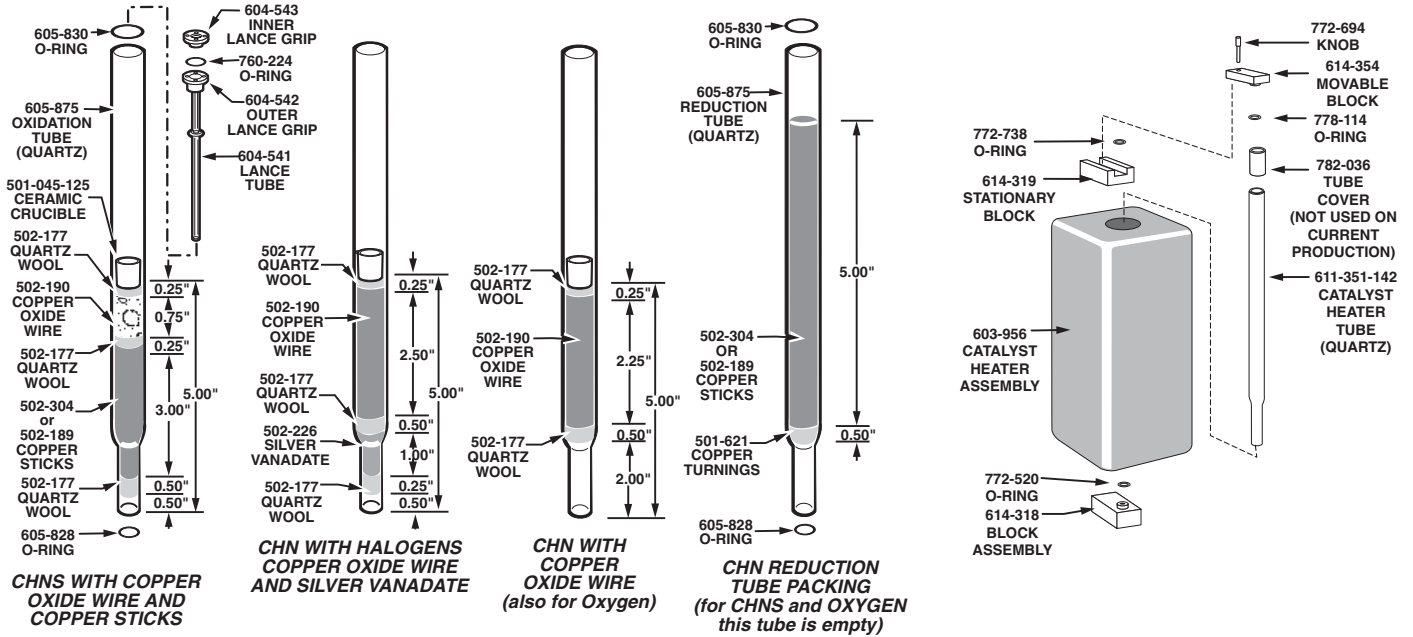

See reverse side for contact information

COMBUSTION/PYROLYSIS SUPPLIES

501-171-HAZ Anhydrone 454 g (1 lb.) bottle
 502-196 Carbon Black 10 g bottle
 502-190 Copper Oxide Wire 100 g bottle
 502-189 Copper Sticks 100 g ampule
 502-304 Copper Sticks 100 g bottle
 501-621 Copper Turnings
 501-081 Glass Wool 454 g (1 lb.) box
 763-265 Glass Wool 227 g (0.5 lb.) package
 606-026 Graphite Crucible 10/package
 502-228 Graphite Pad 1 each
 502-174-HAZ Lecosorb 500 g bottle
 603-340 Microsample Liquid Kit, includes: 500 each
 502-283 Sorbits™ for suspending liquid samples,
 100 each 783-246 Micro-Pipettes for handling liquid
 samples, one (1) 603-341 Capsule Holder
 502-177 Quartz Wool 50 g package
 502-206 Silver Capsules 1000/bottle
 502-226 Silver Vanadate 10 g bottle
 502-227 Tin Capsule 500/bottle
 501-045-125 Zircon Crucible 25/package

COMBUSTION TUBES/GLASSWARE

611-351-142 Catalyst Tube, requires one (1) 772-520 Top
 O-ring, and one (1) 772-520 Bottom O-ring for sealing
 608-065 Graphite Lance
 608-130 Inner Pyrolysis Tube, requires one (1) 608-089 O-ring
 604-540 Lance Assembly, includes: 190-423 Screw (2 req'd),
 604-541 Lance, 604-542 Outer Lance Grip Ring,
 604-543 Inner Lance Grip, 760-224 O-ring
 608-129 Outer Pyrolysis Tube, requires one 608-090 O-ring,
 and one 608-091 O-ring
 774-638 Reagent Tube, requires 772-520 O-rings for sealing
 775-601 Reagent Tube, requires 772-520 O-rings for sealing
 605-875 Reduction and Oxidation Tube Furnace, requires one
 605-828 O-ring, and one 605-830 O-ring

OPERATION ACCESSORIES

601-964 Crimping Pliers
 606-114 Crucible Extractor Tool
 604-538 Filter, 15 micron
 775-306 Secondary Filter, 10 micron
 775-307 Filter Tool/Thumbscrew
 502-023 Funnel, Quick Disconnect
 778-321 Lance Extractor Tool
 502-213 Leak Detection Solution, 4 oz.
 601-483-100 Printer Paper
 601-484 Printer Ribbon
 608-135 Pyrolysis Tube Extractor Tool Assembly
 778-405 Sample Storage Block
 501-241 Vacuum Grease, 5.3 oz.
 601-982 Spatula, Micro
 502-051 Tweezers, Curved

SET-UP STANDARDS**SUCROSE (20 grams)**

Part No.	% C	% H	% N	% O	% S
501-046	42.10	6.48	—	—	—

SUCROSE (50 grams)

Part No.	% C	% H	% N	% O	% S
501-441	42.10	6.48	—	—	—

SET-UP STANDARDS (continued)**POTASSIUM BIPHTHALATE (20 grams)**

Part No.	% C	% H	% N	% O	% S
501-048	47.05	2.47	—	—	—

ACETANILIDE (10 grams)

Part No.	% C	% H	% N	% O	% S
501-053	71.09	6.71	10.36	11.84	—

BENZOIC ACID (10 grams)

Part No.	% C	% H	% N	% O	% S
502-184	68.85	4.92	—	26.23	—

EDTA (50 grams)

Part No.	% C	% H	% N	% O	% S
502-092	40.80–41.20	5.46–5.54	9.52–9.60	—	—

EDTA (250 grams)

Part No.	% C	% H	% N	% O	% S
502-092-250	40.80–41.20	5.46–5.54	9.52–9.60	—	—

DURENE (10 grams)

Part No.	% C	% H	% N	% O	% S
502-101	89.49	10.51	—	—	—

STEARIC ACID (5 grams)

Part No.	% C	% H	% N	% O	% S
502-203	76.00	12.76	—	—	—

DINITROBENZOIC ACID (5 grams)

Part No.	% C	% H	% N	% O	% S
502-204	40.39	1.92	11.54	46.15	—

CAFFEINE (5 grams)

Part No.	% C	% H	% N	% O	% S
502-205	49.48	5.15	28.87	16.50	—

CYSTINE (5 grams)

Part No.	% C	% H	% N	% O	% S
502-207	29.99	5.03	11.65	26.65	26.68

SULFAMETHAZINE (5 grams)

Part No.	% C	% H	% N	% O	% S
502-209	51.78	5.07	20.13	11.5	11.52

CERTIFIED REFERENCE MATERIALS**WHITE MINERAL OIL (4 oz./118 ml)**

Part No.	% S	Part No.	% S
502-417	0.01	502-421	1.0
502-418	0.05	502-422	2.0
502-419	0.10	502-423	3.0
502-420	0.50		

DIESEL FUEL (4 oz./118 ml)

Part No.	% S	Part No.	% S
502-424	0.01	502-429	1.0
502-425	0.03	502-430	2.0
502-426	0.05	502-431	3.0
502-427	0.10	502-432	4.5
502-428	0.50		

NOTE: Part numbers and standards' values may change.
 Consult LECO for latest information.

United States:

Ph: 1-800-292-6141

Fax: 269-982-8977

Canada:

Ph: 1-800-268-0215

Fax: 905-564-6582

represented by:

Other Countries:

Ph: 269-983-5531

Fax: 269-983-3850

© 2010 LECO Corporation